

## Rotor Seal Fitting Procedure Update

**Dated:** 30 July 2007

### Rotor Seal :

The rotor seal arrangement has been changed since machines 17S EG 09, 20CJ 03, 14 YO 01, 10 SD 01, 80 IK 01 and 115 KL 01 .

The new seal assembly uses a combination of a braided seal (FP140-007-0017) on the outside in conjunction with a newer design lip seal (701822) and both seals are retained by a retro-fit flat retainer plate.( FP140-007-0026) ( see diagram Below). These can be used with all previous models.

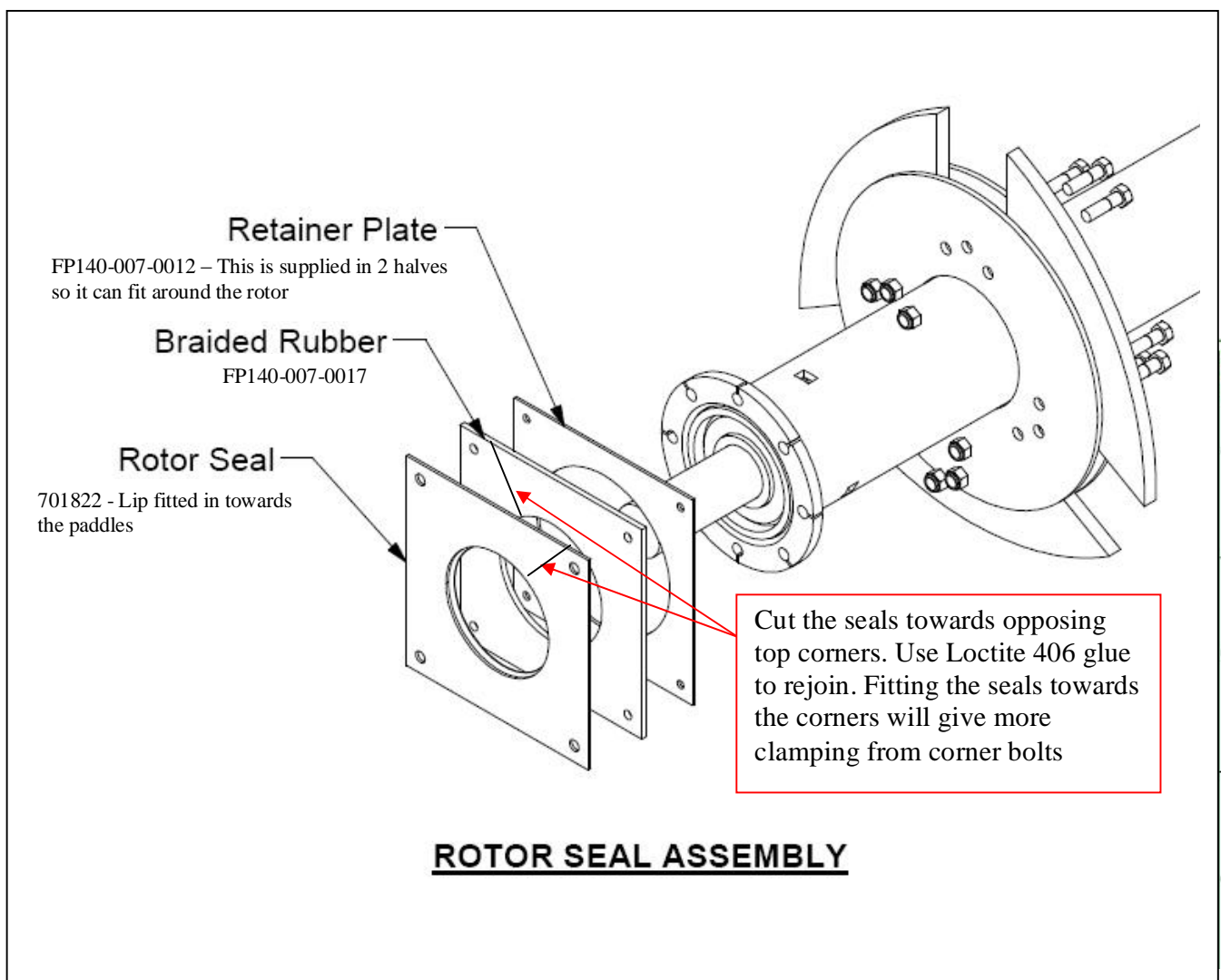

### **Notes**

For a period the machines were manufactured with the bolts welded to the front panel of the machine which make it awkward to replace the seals. In this case we have a procedure for fitting an external box to mount the seal on. If required please contact Keenan Service.

The braided seal is strong and protects the lipped seal against long material. The lipped seal is a tight seal to the rotor for finer materials and liquids.

All part numbers stated are for the 140-200 models.